

RSI standard CaseJet™ printing systems use bulk Ink Management Systems (IMS), to supply printheads and monitor ink levels.

- Maximize uptime, using a bulk ink supply system that allows you to keep the line moving without having to stop to change supplies
- Easily integrate into any environment with gravity fed ink supplies in rugged enclosures that are easy to install and use.
- Keep the environment clean and contaminant free with self-contained, genuine HP printheads and supplies—no spills, bottles or priming

OR

Choose the more robust IMS+ system to make the most of the CaseJet experience.

- Stay alert to ink levels with both audible and visual cues and ink-type mismatch detection.
- Protect inks from dust and other industrial contaminants with stainless steel enclosures.
- Increase versatility in ink stall locations with pressurized ink delivery, front panel controls with LCD screen and independent or integrated regulation.
- Easily integrate into MVP series controllers with Serial port connectivity.



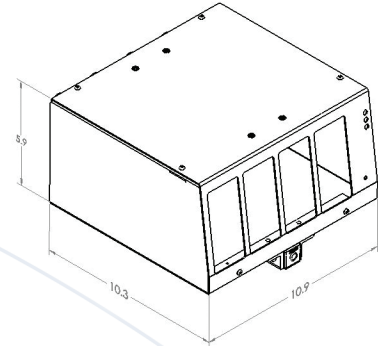
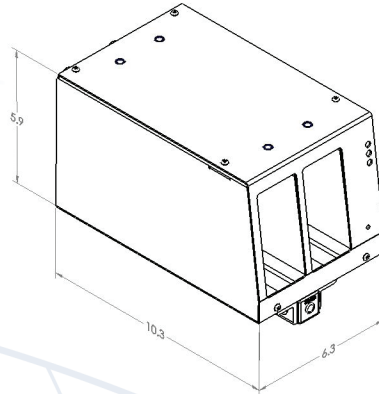
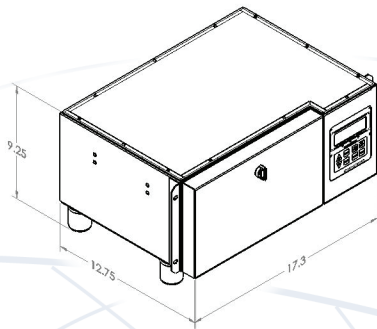

Specifications	IMS+	Standard IMS
Systems Capability	<ul style="list-style-type: none"> • Quad ink supply station • Low Ink warning (Audio and Visual Display) • Online Ink volume displayed in ml • Ink type mismatch detection 	<ul style="list-style-type: none"> • Single, Dual, Quad Ink Supply • Ink level warning with RSI SW
Network Connection	TCPIP/Serial (Proprint Enabled)	NA
Front Panel Interface	Intuitive User friendly front panel control and LCD display	NA
Inks Supplies Type	350ml ink cartridge	350ml ink cartridge
Inks/Color	HP Standard Black, IMS Red	HP Standard Black, IMS Red
Delivery Systems	Pressurized Bulk ink delivery	Gravity system
Stand type	Rack/Post Mountable (19" Rack)	Post mount
Electrical power	90-264VAC, 47-63Hz, 2.0A	NA
Distance from Regulator (ft)	20	8.0