

MVP PLUS INDUSTRIAL INKJET CONTROLLER



The MVP Plus controller offers all the features of the CaseJet Pro in an affordable feature packed compact unit for accurate high-resolution coding.

- **Maximize uptime** using an industrial flash drive, one-button backup and accurate ink-level gauges
 - No hard drive failure
 - No moving parts
 - Backup data to protect against corruption
 - Easily swap printing supplies before empty
- **Rely on scannable barcodes** with consistent, highresolution printing that conforms to required specifications. Bar width adjust assures barcodes are scannable.
- **Get the right message on the right case**, thanks to attached handheld scanners and four levels of security
 - Minimize errors when loading new jobs
 - Minimize operator intervention when changing jobs
 - Prevent unauthorized changes
- **Print in hostile environments** with a robust, easy-to use system that delivers the following:
 - Up to 4 inches of printing
 - Rugged industrial enclosure
 - 15-inch touchscreen interface
- **Easily integrate** into existing systems using built-in Serial, TCP/IP and OPC interfaces.

PLUS

- **Variable data printing** on multi-SKU product lines and increased ease of use.
- **Avoid production stops** with error warnings, using IMS+ ink management solutions
- **Increase accuracy** when printing variable data, using an integrated, multi-SKU database and user friendly case-coding software.
- **Store hundreds of jobs** for fast data and job retrieval.
- **Improve Ease of data input** with built-in keyboard.



RELIABLE. SCANNABLE. INDUSTRIAL.

Technical Specifications

Number of Printheads
Up to 2 x 2" printheads

Print Speed
500 ft/min @ 150 dpi
333 ft/min @ 200 dpi
250 ft/min @ 300 dpi
125 ft/min @ 600 dpi

Enclosure
MVP Plus- Rugged Industrial enclosure

Ink
IMS Plus Ink System
Standard IMS available

Inputs/Outputs

External Communication
RS-232, Ethernet, USB

External Inputs
Sensor input
Encoder Input
Symbol handheld scanner w/RS-232 interface

External Outputs
Integrated warning light

Operator Interface
15" Resistive touch screen LCD

Keyboard and Pointer
Optional Keyboard and Mouse available

Part Numbers

Systems
P/N 12066, MVP Plus System
P/N 12088, MVP Plus System w/ IMS Plus

* Refer to Printhead and mounts datasheet for more details.

Accessories
P/N 12169, SCSI Adapter Cable to Cable
P/N 9697, Cable 10' SCSI
P/N 9698, Cable 20' SCSI
P/N 8628, Fan covers
P/N 12144, SW Multi production line function
P/N 12143, Tool kit

Warranty
One (1) Year Parts; 90 Days Labor

System

Operator Interface
Full color LCD touch screen

Database
Job selection via internal Access database

Password Protection
4 Tier Security User Levels

Integration
TCP/IP, Serial, and OPC connectivity

On Board CPU
Industrial Flash drive
1G RAM

Operating System
1.5 GH Via Processor
Windows XP Embedded, SP2

Print Capability

Fonts
Windows Open, Windows True Type

1D Barcodes
Interleaved 2 of 5, UPC A, UPC E, EAN-13,
EAN-8, Planet, Code 39, Code 128, Codabar/
NW-7, RSS

2D Barcodes
Data Matrix, PDF 417

Objects
Date/time codes, shift codes, user Inserts,
static text, bitmaps, conditional bitmaps, and
counters

Services

Power Supply
110-240 VAC, 50/60 HZ,
MVP Plus/w IMS Plus (9A)

Sensors
DB 9 (female on controller)
Pin out:
P3- Hi (PNP), P6- GN, P7- Low (NPN)
P8- +12VDC

* Do not connect other pins
Encoders
DB 9 (female on controller)
Pin out:
P1- +5VDC, P2- GN, P3- Low (NPN)

* Do not connect other pins

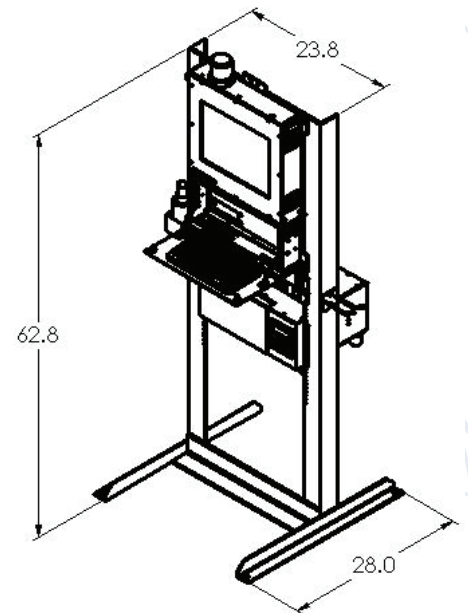
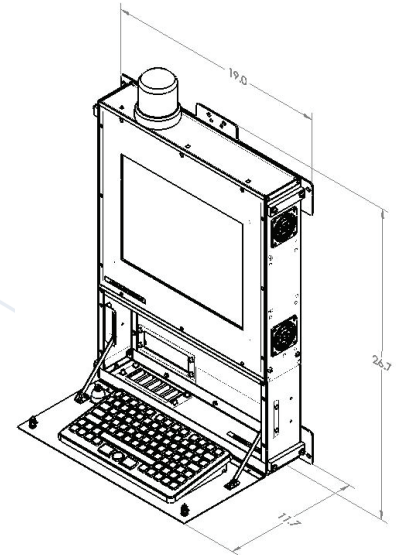

WE WANT TO HEAR FROM YOU.

1-866-PRINT HP (1-866-774-6847)

sales@rsipro.com
www.rsipro.com

HEADQUARTERS

8345 Beechcraft Ave. Suite J
Gaithersburg, MD 20879

ASIA PACIFIC OFFICE

Blk 4008 Ang Mo Kio Ave 10
#02-19 Techplace I
Singapore 569625
Phone: +65 64584620